



RS625

AUTOMATIC TRANSMISSION

WITH SEPERATE LOCK/UNLOCK BUTTONS

**REMOTE START SYSTEM
PRODUCT MANUAL**

Remote Transmitters

Remote Transmitter Description



The **RS625** is a state-of-the-art remote starting system is supplied with two 4-button Remote Transmitters used to control system operations.

The built-in remote start feature is designed to offer maximum convenience by remote starting your vehicle's engine, turning on the heater/air conditioner, and then running for a pre-determined time to provide a comfortable environment once you enter your vehicle.

Accele Electronics and its VENDORS shall not be liable for any accident resulting from the use of this equipment. This system is designed to be professionally installed into a car or vehicle in which all items, such as parking brake and all associated components, Hood switches, transmission shift linkage, throttle linkage, and all engine safety features, are in perfect working condition.

Do not ever Install RS625 in vehicles equipped with MANUAL TRANSMISSION.

DO NOT remote start the vehicle in a closed garage. Make sure that the garage door is open or there is adequate ventilation. Failure to observe this rule could result in injury or death from poisonous Carbon. To ensure the safety and security of the system while it is remote started, the G40RS Starter employs several safeguards. In the event the brake pedal is pressed while the engine is remotely running, the remote start will immediately shutdown to prevent unauthorized users from attempting to drive the vehicle. The system is equipped with a hood pin input to prevent access to the engine compartment while the vehicle is remotely running. Finally, the Valet Mode prevents the remote start feature from operating in the event the vehicle is to be serviced.

Button 1 Locks the doors and when held for 5 seconds, activates the system's Car locator feature.

Button 2 unlocks the doors.

Button 3 N.A

Button 4 Activates and deactivates the Remote Start feature.

Adding/Replacing Transmitters

To replace lost or stolen transmitters or to add additional transmitters into the system, have all desired transmitters ready and follow the steps below.

Note: Up to four transmitters can be programmed to operate the system. To erase any previously stored transmitter codes, be sure to program all 4 transmitter memory locations.

To program transmitter(s):

1. Turn the ignition key On, Off, On, Off, and back On.
 - The parking lights will flash 3 times.
2. Press and hold the Override switch for 5 seconds.
 - The parking lights will flash 5 times.
 - The LED will illuminate.
3. Press Button 1 on the first transmitter.
 - The parking lights will flash once.
4. Repeat steps 3 and for each transmitter (up to 4).
5. Turn off the ignition key.
 - The parking lights will flash 3 times.

System Operation

Remote Locking

To Lock the doors:

1. Turn off the ignition.
2. Press Button 1.
 - The doors will lock.
 - The parking lights will flash once.
 - The LED will turn on, to indicate the doors are locked.
3. 10 seconds after Locking:
 - The LED will start blinking.

Remote Unlocking

To Unlock the doors:

- Press Button 2.
- The doors will unlock.
 - The parking lights will flash twice.
 - The LED will turn off .

Remote Starting Automatic Transmission Mode

To Remote Start the System:

1. Be sure the system is not in Valet Mode.
2. Press and hold Button 4
 - The parking lights will flash twice.
 - The doors will lock (programmable)
 - The engine will start and run for the duration of its programmed Run Time.
 - The heater or air conditioner will turn on (if turned on prior to exiting the vehicle).

To resume control of the vehicle:

1. Unlock the doors manually or with the Transmitter.
2. Turn on the ignition.
3. Press the Brake Pedal to disengage the remote start.

Visual Car Locator Mode

Use this feature to locate your vehicle in a crowded parking lot. Look for the flashing parking lights which should be your vehicle!

To activate the Visual Car Locator Mode:

1. Press and hold Button 1 for 3 seconds.
 - The parking lights will flash.
 - The doors will unlock allowing access to the vehicle.
2. Press Button 2 to turn off Car Finder.

Valet Mode

The Valet Mode temporarily disables the remote start system so the vehicle may be serviced by a mechanic. The remote transmitters will continue to lock/unlock the doors.

To activate or deactivate the Valet Mode:

1. Turn on the ignition.
2. Press and hold the override switch for 5 seconds.
 - The parking lights will flash once and LED will be On to confirm the Valet Mode is on or twice and LED will turn off to confirm Valet Mode is off.
3. Turn off the ignition.

Shut Down

When the the Remote Start feature is active, any of the following actions will shutdown the engine:

1. Pressing Button 4
 - After the engine shuts down the doors will lock (programmable)
2. Pressing the Brake Pedal.
3. Opening the Hood.
4. Remote Start Time-Out (completion of the timed run cycle).

Quick Stop (Automatic Transmission Only)

The Quick Stop Feature allows you to exit the vehicle while keeping the engine running for quick stops.

To leave the vehicle running:

1. Press Button 4 .
2. The parking lights will turn on. Now turn the ignition key off and the vehicle will continue to run.
3. You may now exit the vehicle and lock the doors manually or by using the Remote Transmitter.

To resume control of the vehicle:

1. Unlock the doors manually or with the Transmitter.
2. Turn on the ignition.
3. Press the Brake Pedal to disengage the remote start.

Automatic Start Mode

The Automatic Start Mode allows the vehicle to automatically start the vehicle every one or two hours and run for the preset Run Time.

To turn on Auto Starting:

1. Turn Ignition switch Off and wait for 3 seconds.
2. Turn Ignition switch On and Off three times ending with Ignition in Off position
3. Press and release the Valet switch immediatly.

Parking lights will flash indicating that the Auto Start mode has been activated.

To turn off Auto Starting do one of the following:

- Turn ignition On.
- Arm and then Disarm the system
- Alarm or Panic the system

*** Automatic Start Mode will stay active for 24 hours only.**

Ignition Door Locking

For added safety, the Ignition Door Locking feature allows vehicles equipped with power door lock systems to automatically lock the doors when the ignition is turned on.

Ignition Door Unlocking

For added convenience, this feature automatically unlocks the doors after the ignition key is turned off. The Ignition Door Unlocking feature may also be completely disabled if desired.

Battery Replacement

Your Remote Transmitter uses (2) 3 volt batteries (type CR2016), which will require replacement in time. Depending on the amount of use, the battery may last up to six months or more before it needs replacement.

When the battery needs replacing, the system's operating range will decrease or the transmitter LED may not be as bright.

In order to change the battery, separate the top and bottom halves of the case.

While replacing the battery make sure that the positive and negative terminals are positioned correctly, then carefully reassemble the transmitter case.

Entering System Programming

To enter System Programming:

1. Turn on ignition.
2. Within 5 seconds, press the valet switch 5 times.
 - The parking lights will flash three (3) times indicating you have entered Programming.
3. Press the valet switch the number times equal to the System Parameter you want to change.
 - The parking lights will flash each time the valet switch is pressed.
4. Within 5 seconds, press the transmitter button corresponding to the desired operating mode for that System Parameter.
 - The parking lights will flash to indicate the setting.

1 flash	=	Button 1
2 flashes	=	Button 2
3 flashes	=	Button 3
5. When you are finished, turn off the ignition to save the changes.

Default Reset

Following this procedure will set all System Programming Parameters to factory default settings.

1. Enter System Programming.
2. Press Transmitter Button 3.
 - The parking lights will flash 6 times indicating that the reset signal was received.
 - All System Programming parameters are now set to factory default settings.
 - The Valet Mode is off.

System Programming

Branch	Feature	Button 1 (default)	Button 2	Button 3
1.	Ignition Door Locking	Enabled	Disabled	
2.	Ignition Door Unlocking	Enabled	Disabled	
3.	Door Unlock Pulse	Single	Double	
4.	Door Lock Pulse Length	1 second	3 seconds	0.1 Sec
5.	Lock after Start	On	Off	
6.	Lock after Shutdown	On	Off	
7.	Engine Run Time	15 minutes	25 minutes	
8.	Automatic Start Mode	Disabled	2 hours	1 hour
9.	Tachless Sense Crank Time	Normal	Extended	Super Extended
10.	Engine Type	RPM Mode/RPM Learn	Gas Engine	Diesel Engine
11.	Ignition 2 Output Program	Ignition 2 Output	Accessory 2 Output	Starter 2 Output
12.	Unlock Before Start	Disabled	Enabled	
13.	Horn Chirp	Enabled	Disabled	
14.	Smart Start Run Monitor	Enabled	Disabled	

Jumper Selection

Carefully separate the top and bottom halves of the main unit case. Once the cover is removed, the parking light polarity jumper will be visible next to the parking light relay. Set the jumper for the correct polarity output as described below, then reassemble the main unit case.

Parking Light Output. Selects the polarity (+/-) for the output of the on-board Parking Light relay.

Left Pin + Center Pin = positive

Right Pin + Center Pin = negativ

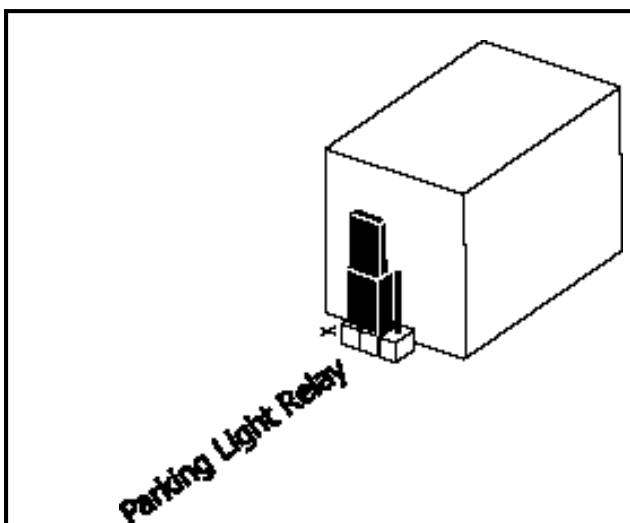

default setting shown

System Installation

8-Pin Main Harness

- Pin 1 **RED WIRE:** Module Power Input (+). Connect to a constant source of +12V
- Pin 2 **GREEN/WHITE WIRE:** Brake Input (+). Connect to the wire that shows +12V when pressing the brake. The Green/white wire is a safety shutdown wire that must be connected.
- Pin 3 **BROWN/WHITE:** Horn Output (-) 500 mA. Connect to a relay to activate the vehicle's horn when the alarm is triggered. This wire may instead be programmed as an ignition 3 relay trigger
- Pin 4 **WHITE WIRE:** Parking Light Output (+/-) relay. Connect the White wire to the circuit that shows +12V or ground only when the parking lights are on and set the internal parking light relay jumper to the proper polarity. For parking light circuits exceeding 10 amps, a relay is required. For vehicle's with independent left and right parking light circuits, diodes must be installed to keep the circuits separate. NOTE: Do not connect the WHITE wire to the vehicle's headlight circuit.
- Pin 5 **WHITE/BLACK WIRE:** Hood Pin Input (-). Connect the to the hood pin switch. The switch must provide a ground output when switch is opened.
- Pin 6 **BLUE/ORANGE WIRE:** Ground When Running Output (-) 500 mA. Connect to an optional factory security bypass module if required.
- Pin 7 **BLACK WIRE:** Ground Input (-). The Black wire must connect to a solid chassis ground. Clean away any paint or dirt to insure the best possible ground.
- Pin 8 **BLACK/GRAY WIRE:** Tach Input. Connect to the vehicle's tach wire or a fuel injector wire if the tachless mode does not provide satisfactory operation.

3-Pin White Door Lock Connector: Door lock port.

2-Pin Blue Connector: Valet switch port. Mount switch where it is accessible from the driver's position.

2-Pin Red Connector: LED port. Mount LED where it may be easily seen from either side of the vehicle.

3-Pin White Door Lock Connector: Door lock port.

- BLUE WIRE - negative unlock output (-) 500mA.
- RED WIRE - (+) 100mA trigger output for optional plug-in door lock relay module,
- GREEN WIRE - negative lock output (-) 500mA.

5-Pin White Flat Connector: Antenna connector port.

Starter Diagnostics

Starter doesn't start and Parking Lights flash:

3 Times - Hood Trigger is active

5 Times - Unit is in Valet (service) mode, and start is disabled.

8 Times - Brake Lights stay On

Door Lock Diagrams

Negative Trigger

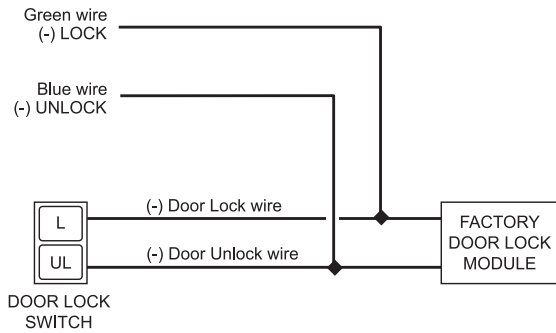

Adding Actuators

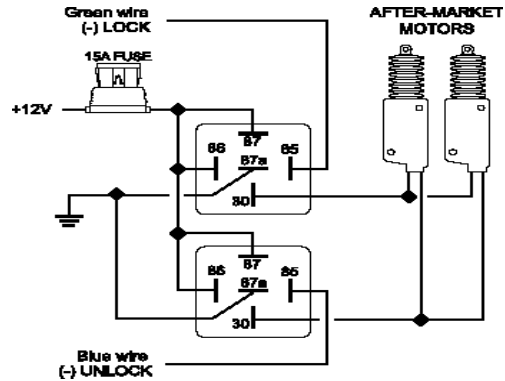

Reverse Polarity

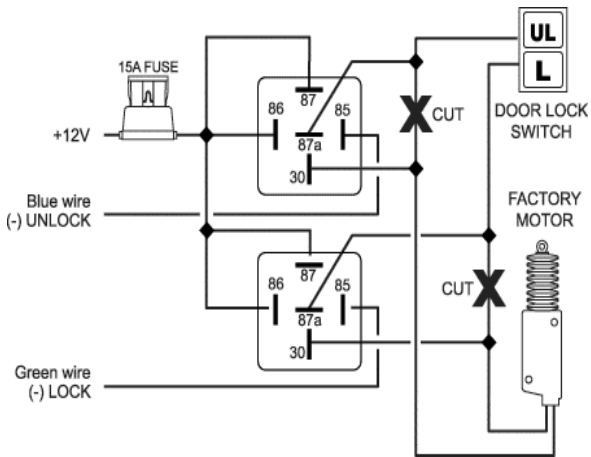

Positive Trigger

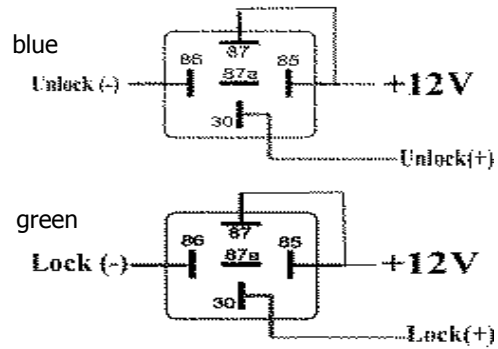

Positive Horn Honk

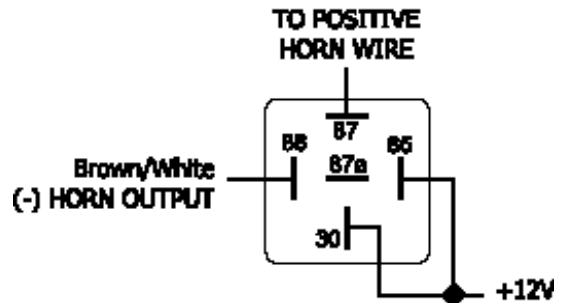

Wiring Diagram

